



# SPRINGTEST 3

## Spring tester



### Tester for tension and compression springs

With its STENTOR II motorized test stand, fixed plate and adjustable plate, this unit can be used to test high capacity tension and compression springs. The command automatically determines the origin of the displacements and then stops the machine at a pre-determined flexion value to measure the height under load.

It is also possible to measure flexion, and cycles can be programmed. The instrument has an RS232, memory card reader or USB to store the results on a computer.

Additional sensors are available to provide high levels of precision for springs with low force levels. These load cells are automatically recognized by the tester using our technology SPIP.

Ready to use system. Supplied with a Ø 100 mm fixed plate and a self-aligning plate to keep the plates parallel during the tests.

Hooks are available as options for tensile testing.

Available in 4 capacities : 250 N, 500N, 1000N and 2000N

#### System includes :

- Motorized tester STENTOR II
- One load cell

- Compression plate Ø 100 mm
- Self levelling plate Ø 80 mm
- Certificat of calibration linked COFRAC

### Models et capacities

SPECIFICATIONS	SPRINGTEST 3-250	SPRINGTEST 3-500	SPRINGTEST 3-1000	SPRINGTEST 3-2500
Capacity	250N	500N	1000N	2000N
Travelling	200 mm	200 mm	200 mm	300 mm
Displacement resolution	0.01 mm	0.01 mm	0.01 mm	0.01 mm
Displacement accuracy	0.05 mm	0.05 mm	0.05 mm	0.05 mm
Space table / crosshead	430 mm	430 mm	430 mm	530 mm
Speed en mm/min	10 à 350	10 à 350	10 à 350	10 à 350
Speed resolution	1 mm/min	1 mm/min	1 mm/min	1 mm/min
Speed accuracy	5 %	5 %	5 %	5 %
High speed	350 mm/min	350 mm/min	350 mm/min	350 mm/min
Mechanical travel limit	Yes	Yes	Yes	Yes
Software travel limit	Yes	Yes	Yes	Yes
Stop on force	Yes	Yes	Yes	Yes
Cycles	Yes	Yes	Yes	Yes
Table dimensions	200 x 300 mm	200 x 300 mm	200 x 300 mm	200 x 300 mm
Stand dimensions	855x345x500	855x345x500	855x345x500	947x345x500
Weight	40 kg	40 kg	40 kg	50 kg
Power supply	220 V	220 V	220 V	220 V

#### Optional hooks for tensile tests on springs



### Specifications

FONCTIONS	SPRINGTEST 3
Accuracy	0,5 % FS
Resolution	1/10 000 FS
Data rate	1 000 Hz
Overload protection	200% FS
Units	N, Lb, Kg, g, Oz
Bargraph	√
Peak in traction and compression	√
Display peak and current reading in the same time	√
Display curve Force / Deflection	√
Tare feature	√
Stop on force	√
Average and standard deviation	√
Automatic calculations	√

FONCTIONS	SPRINGTEST 3
Memory	1000 results, 1 curve
Emergency stop	√
Automatic recognition of force sensors	√
Available load cells	20N, 50N, 100N, 200N, 500N, 1kN, 2kN (version 2500)
Manual high speed	√
Automatic return	√
Manual and automatic tare	√
Safety guard	Option
RS232 output	Current value, peak, calculation
USB output	Current value
Data rate on USB	500 values / second
Backlight	√

# SPRINGTEST 3 Spring tester



Input / Output : USB, RS232, TTL

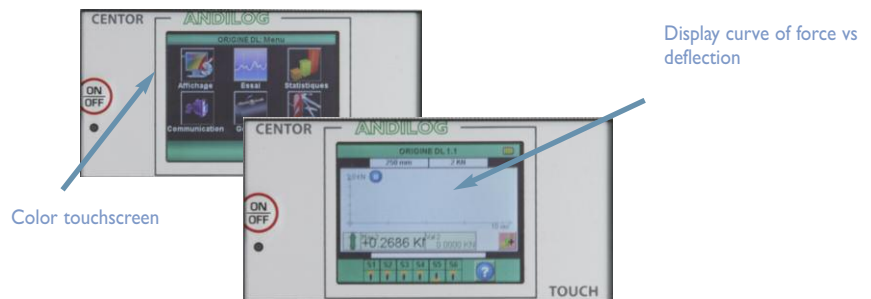

## Options - Software

## Dimensions



Caligraph software compatible : software for curve analysis with USB or RS232 download.  
RSIC software compatible : Download your results to Microsoft Excel



Datastick compatible : Memory card reader to save your data to a SD memory card

### Springtest 3-250/500/1000

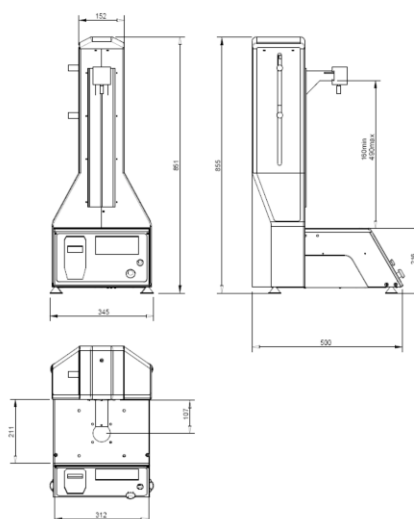

### Springtest 3 -2500

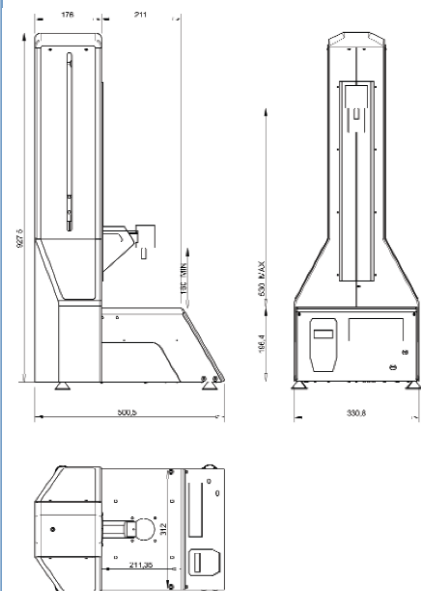

**ANDILOG Technologies**

BP 62001

13845 Vitrolles Cedex 9

info@andilog.com • www.andilog.com

Tél. : +33 820 888 202 • Fax : +33 820 888 902



ISO 9001:2008 certified